

SPINDLE SPEED INCREASERS

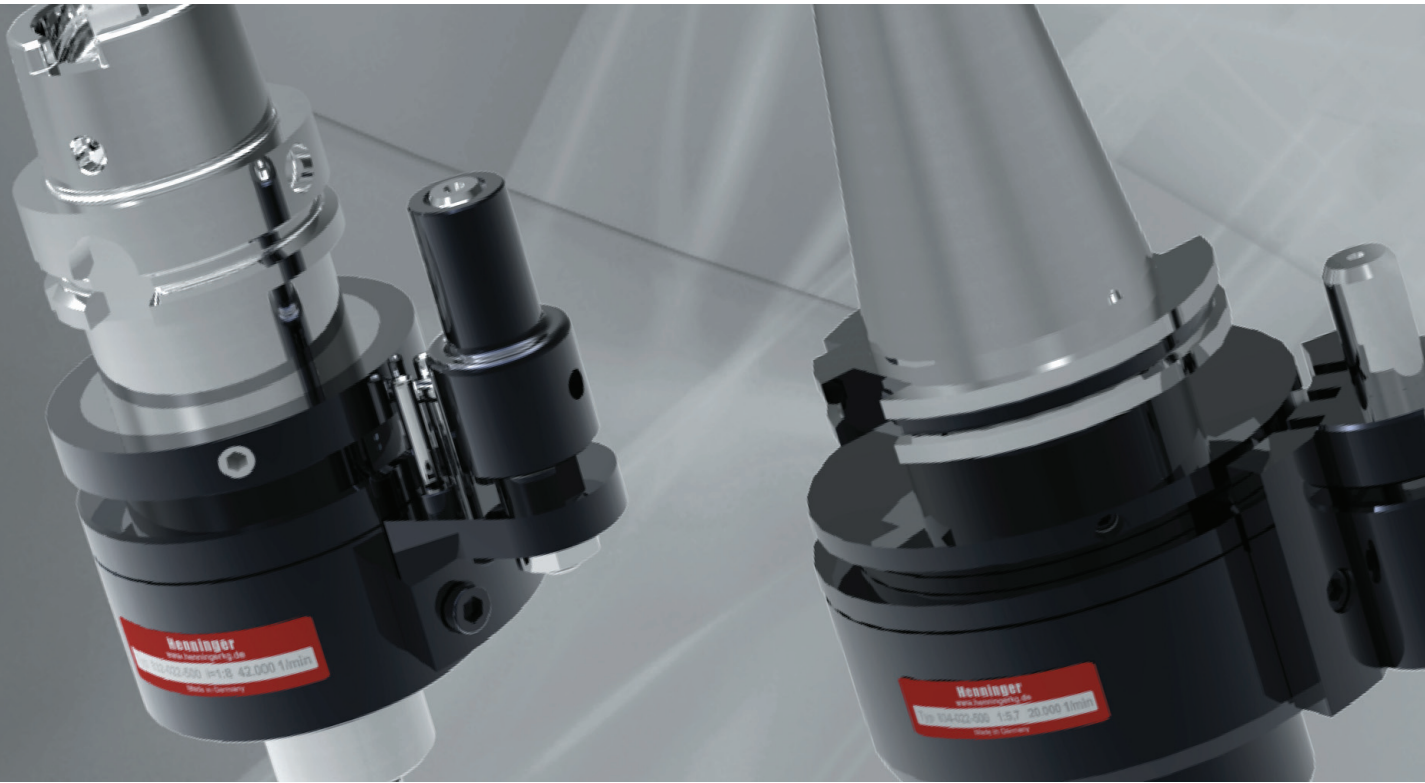

TYPE	832	834	834	815	816	825	826
Drive	modular I	modular I	modular I	modular II	fixed	modular II	fixed
Clamping range	ER 11 Ø1 - 7	ER 25 Ø1 - 16	ER 32 Ø2 - 20	ER 40 Ø2 - 30	ER 50 Ø4 - 34	ER 40 Ø2 - 30	ER 50 Ø4 - 34
Ratio	1 : 7.7	1 : 5.7	1 : 5.7	1 : 4	1 : 4	1 : 4	1 : 4
max. pressure inner coolant	50 bar	50 bar	50 bar	Supplied per machine specifications			
RPM min-1/Power kW / 20% DF*	50,000 / 6.1	20,000 / 7.2	20,000 / 7.2	10,000 / 7.5	9,000 / 18	14,000 / 10.5	12,000 / 24
RPM min-1/Power kW / 80% DF*	42,000 / 5.1	15,000 / 6.0	15,000 / 6.0	8,000 / 6.0	7,000 / 14	10,000 / 7.5	10,000 / 20
RPM min-1/Power kW / 100% DF*	36,000 / 4.4	12,000 / 4.8	12,000 / 4.8	6,400 / 4.85	5,600 / 12.8	8,000 / 6.0	8,000 / 16
max. Torque (Nm)	1.2	3.8	3.8	7.16	19.1	7.16	19.1
approx. weight with shank / kg	3.2 / SK 40	9.8 / HSK 100	9.8 / HSK 100	10.5 / SK 50	22.6 / SK 50	15.3 / SK 50	24.9 / SK 50

*DF = Working time per hour

Air-Speeder Type 848 / 852

Optimum speed for small tools
Interchangeable shanks
High efficiency turbo - motor
Available for automatic tool change

Permanent lubrication
Quiet in operation
High precision preloaded bearings
Air supply central or lateral

TYPE	848	852
Input shank modular	all common shanks	all common shanks
Tool holder	Collets DIN 6499	Collets DIN 6499
Clamping range	Ø 1 - 7mm	Ø 1 - 7mm
max. speed min⁻¹	80,000	48,000
max. power Watt	810	1080
Air consumption L/min	280	440
Power at 5 bar approx. Watt	540	720
Abrasive wheel Ø max.	6	13
Spindle bearings pc.	2	2
Lubrication	permanent grease lubrication	permanent grease lubrication
Weight with modular shank SK 40 approx. kg	2.8	3.8

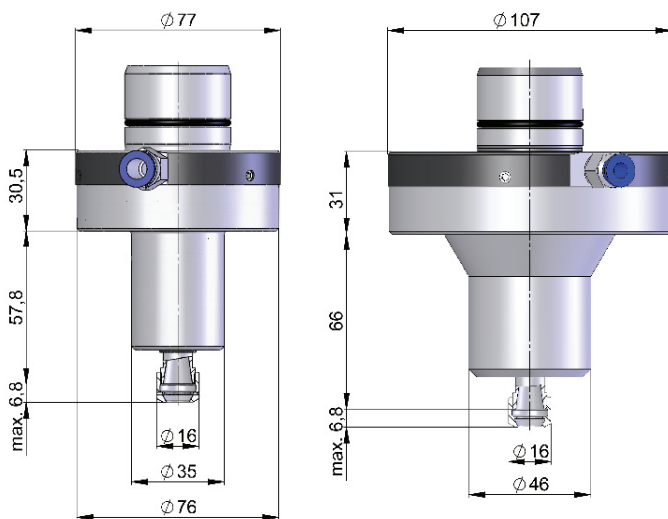

Also available, high speed motor spindles up to 80,000 rpm and 15kW power



16 E. Piper Lane, Suite 128 (847) 749-0633
Prospect Heights, IL 60070 info@platinumtooling.com

Visit us online: www.platinumtooling.com • Or call us: 847-749-0633